



# TAI-SAW TECHNOLOGY CO., LTD.

No. 3, Industrial 2nd Rd., Ping-Chen Industrial District,  
Taoyuan, 324, Taiwan, R.O.C.

TEL: 886-3-4690038 FAX: 886-3-4697532

E-mail: [tstsales@mail.taisaw.com](mailto:tstsales@mail.taisaw.com) Web: [www.taisaw.com](http://www.taisaw.com)

## Approval Sheet For Product Specification

Issued Date: 9/13/2004 (REV. NO: 1)

Product Name: SMD 5.0x3.2 78.125MHz Crystal Unit

TST Parts No.: TZ0430A

Customer Parts No. : \_\_\_\_\_

Company: _____
Division: _____
Approved by: _____
Date: _____

Checked by: \_\_\_\_\_ Ann Liu

Approval by: \_\_\_\_\_ TF Yang

Date: \_\_\_\_\_ 9/13/2004



# TAI-SAW TECHNOLOGY CO., LTD.

No. 3, Industrial 2nd Rd., Ping-Chen Industrial District,  
Taoyuan, 324, Taiwan, R.O.C.

TEL: 886-3-4690038 FAX: 886-3-4697532

E-mail: [tstsales@mail.taisaw.com](mailto:tstsales@mail.taisaw.com) Web: [www.taisaw.com](http://www.taisaw.com)

## SMD 5.0x3.2 78.125MHz Crystal Unit

MODEL NO.: TZ0430A

REV. NO.: 1

### Features:

- Surface Mount Seam Weld Package
- Ultra Miniature Package

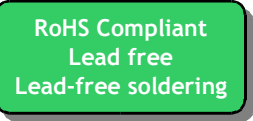

### Description and Applications:

Surface mount 5.0mmx3.2mm crystal unit for use in wireless telecommunications devices, especially for a need of ultra miniature package for mobility.

### Electrical Specifications:

TZ0430A	Specification
Nominal Frequency	78.125000 MHz
Mode of Oscillation	3 <sup>rd</sup> Overtone
Storage Temperature Range	-45°C to +90°C
Operating Temperature Range	-40°C to +85°C
Frequency Stability over Operating Temperature Range	+/-25 ppm (referred to the value at 25°C)
Frequency Make Tolerance (FL)	+/-25 ppm @ 25°C +/- 3°C
Equivalent Series Resistance (ESR)	60 Ω max
Nominal Drive Level	100 uW
Shunt Capacitance (Co)	5 pF max
Load Capacitance (CL)	5 pF
Insulation Resistance	500 MΩ min./DC 100V
Marking	Laser marking

# Mechanical Dimensions (mm):

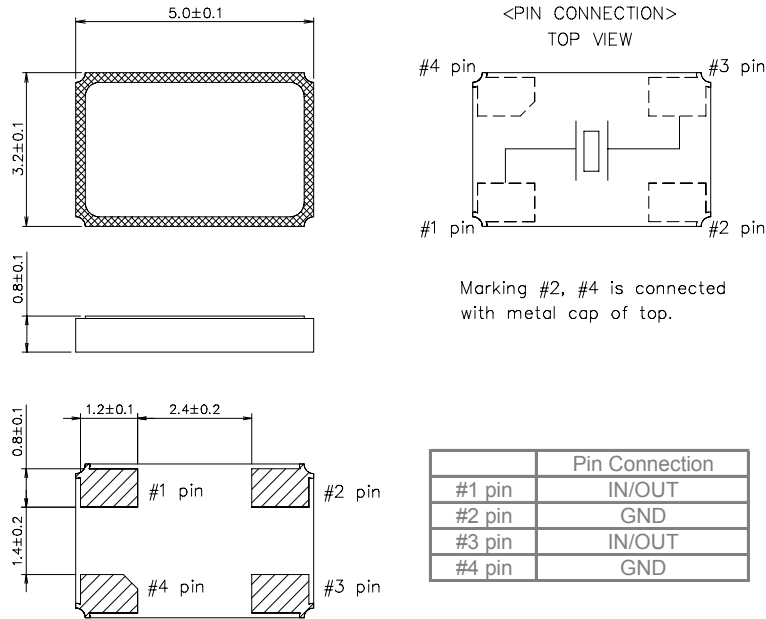

# Recommended Land Pattern: (unit: mm)

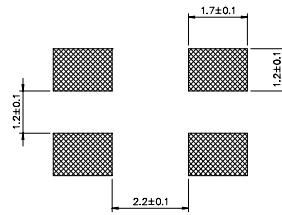

# Marking:

Line 1: Frequency (78.125)

Line 2: TST Logo + Crystal Product Code + Date Code

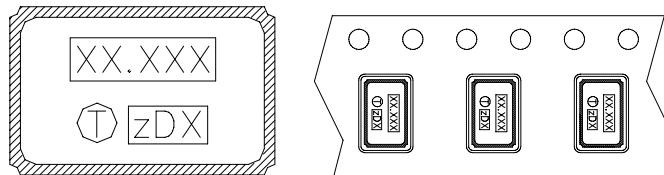

# Product Code Table

Year	2001	2002	2003	2004
	2005	2006	2007	2008
Product Code	Z	z	<u>Z</u>	<u>z</u>

# Date Code Table

WK01	WK02	WK03	WK04	WK05	WK06	WK07	WK08	WK09	WK10	WK11	WK12	WK13
A	B	C	D	E	F	G	H	I	J	K	L	M
WK14	WK15	WK16	WK17	WK18	WK19	WK20	WK21	WK22	WK23	WK24	WK25	WK26
N	O	P	Q	R	S	T	U	V	W	X	Y	Z
WK27	WK28	WK29	WK30	WK31	WK32	WK33	WK34	WK35	WK36	WK37	WK38	WK39
a	b	c	d	e	f	g	h	i	j	k	l	m
WK40	WK41	WK42	WK43	WK44	WK45	WK46	WK47	WK48	WK49	WK50	WK51	WK52
n	o	p	q	r	s	t	u	v	w	x	y	z

## Reel Dimensions (mm):

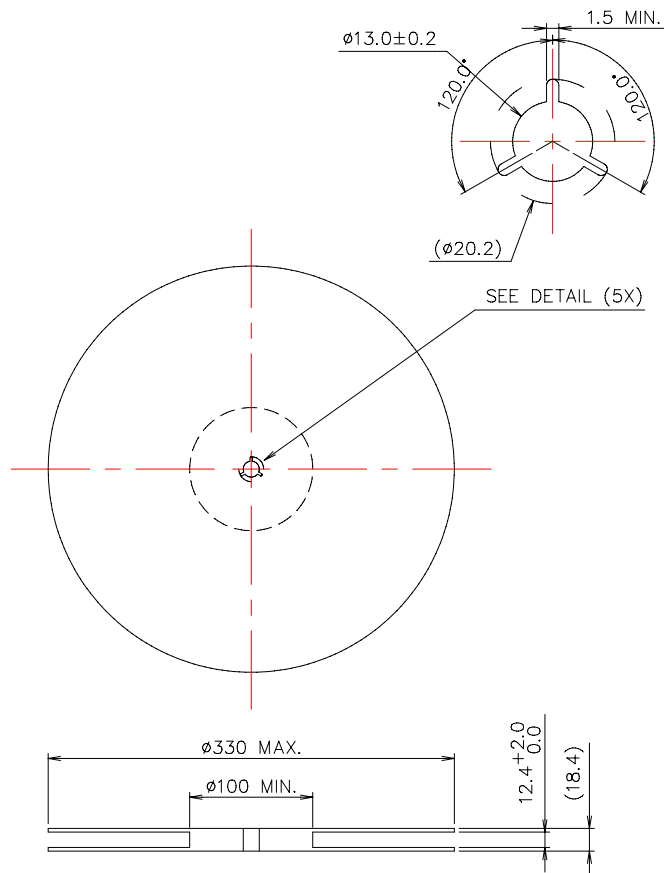

## Tape Dimensions (mm):

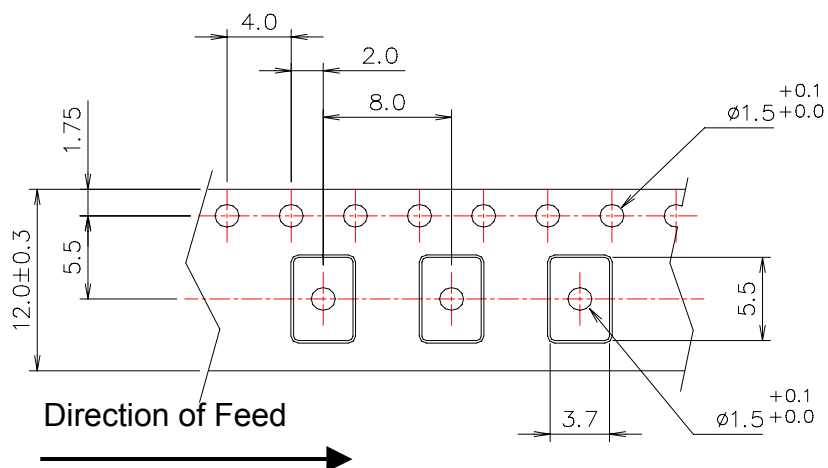

### [NOTE]:

1. Unless otherwise specified tolerance on dimension +/-0.1 mm.
2. Material: conductive polystyrene with color black.
3. 10 pitch cumulative tolerance +/-0.2 mm.

# Reflow Profile:

1. Preheating shall be fixed at 140 ~ 160 °C for 60 ~ 90 seconds.
2. Ascending time to preheating temperature 150 °C shall be 30 seconds min.
3. Heating shall be fixed at 200 °C for 50 ~ 60 seconds and at 230±10 °C peak.

